

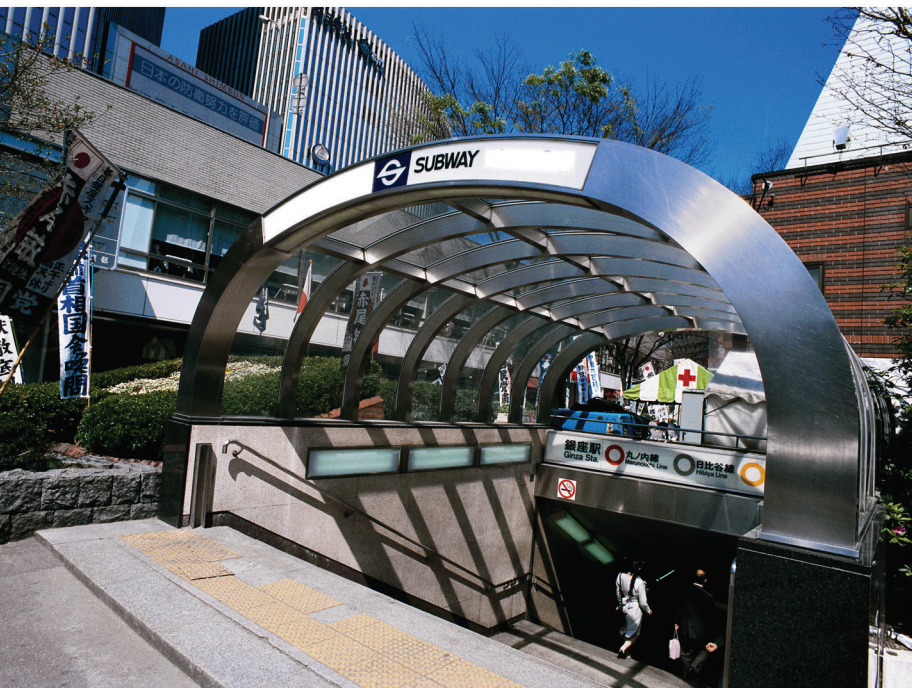

IN-BUILDING COMMUNICATION ENHANCEMENT SYSTEMS



OUR PRODUCTS ARE MADE IN
THE USA AND INCLUDE



A 5 YEAR
WARRANTY



INTRODUCTION TO EMR CORPORATION COMMUNICATION ENHANCEMENT SYSTEMS

By:
William F. Lieske, Sr.
Founder, EMR Corporation

As SMR (trunking) systems gained popularity in the 1980's and high performance portable radio transceiver units for these systems became available, an upsurge of portable usage took place. It was quickly found that portable coverage into and out of buildings, tunnels and areas deeply shaded from the base station site suffered from intermittent to a complete lack of coverage.

The idea of enhancement coverage using uni-directional or bi-directional filter-amplifiers provided an answer to the problem. Placing an antenna array in the clear, aimed at the remote site provides access to the communications system. Either "lossy" line or hard line with properly located antennas throughout the areas to be covered, provides distribution of the desired signal.

EMR Corporation began work in this very specialized area in 1985 with enhancement systems located in city and county jail facilities. Soon, tunnels, state and federal correctional facilities, airports, gambling casinos and semiconductor fabrication plants were equipped with enhancement systems. Many cities throughout the world require, as part of their building code, enhancement systems for public safety communications within large or underground structures. Shopping malls, convention centers and multi-story office buildings have been enhanced to provide communications for police, fire and emergency medical aid, as well as routine administrative operations. Extending communications into such areas for safety and site security is fast becoming the rule, rather than the exception.

EMR engineers found that suitable amplifiers for optimum enhancement system performance could not be found on the market. After an analysis of system requirements, we have designed special amplifiers to meet this need.

Using our experience in broad band filter design, we developed very effective filtering components. We now have a complete, mature line of enhancement system products. These include multi-band and cross band systems that will handle midband, FM broadcast, VHF, UHF, cellular, 800 and 900 MHz SMR, PCS and VHF, UHF and 900 MHz paging operations. Our enhancement systems perform equally well for digital or analog radio communications system applications.

Over the years we have built solid experience in a wide variety of signal enhancement systems in the spectrum from 66 MHz to 960 MHz. To support these systems we maintain stocks of all active amplifiers and power supplies for immediate replacement. We warranty our enhancement systems for 5 full years from date of shipment.

EMR Corporation can design a system for you or provide assistance in the development of a plan for a suitable enhancement system design. Your needs can be met with an EMR Corporation signal enhancement system.

No enhancement project is too large or too small for EMR, please contact our engineers. We know you will be impressed with our approach, knowledge and suggestions.

APPLICATION NOTES FOR COMMUNICATION ENHANCEMENT SYSTEMS

WHERE IS SIGNAL ENHANCEMENT USED?

In buildings, tunnels, and areas that are shaded from adequate RF Signal coverage.

WHAT ARE THE BENEFITS?

Signals from a remotely located trunking or pager site are received and amplified with radiating elements distributed as needed to provide desired coverage. Using the same distribution cables and/or antennas, portable radio signals are filtered and amplified sufficiently to provide full coverage. The "donor" site must be near enough to the enhanced site to provide a minimum of signal strength relative to ambient and system noise. These levels are usually determined by field measurements.

WHAT ARE BI-DIRECTIONAL AND UNI-DIRECTIONAL AMPLIFIER SYSTEMS?

A bi-directional system provides filtering and amplification both to and from the remote site. A uni-directional system provides one-way filtering and amplification.

WHAT DOES THE DISTRIBUTION SYSTEM CONSIST OF?

Coaxial transmission lines and accessory devices such as power splitters, hybrid couplers, sampling line taps and suitable antennas that are strategically placed. The use of "lossy line" cable is often used, particularly in tunnels and long corridors. The choice of distribution method depends on the nature of the structure in which signal enhancement is required.

TYPICAL BI-DIRECTIONAL ENHANCEMENT SYSTEM

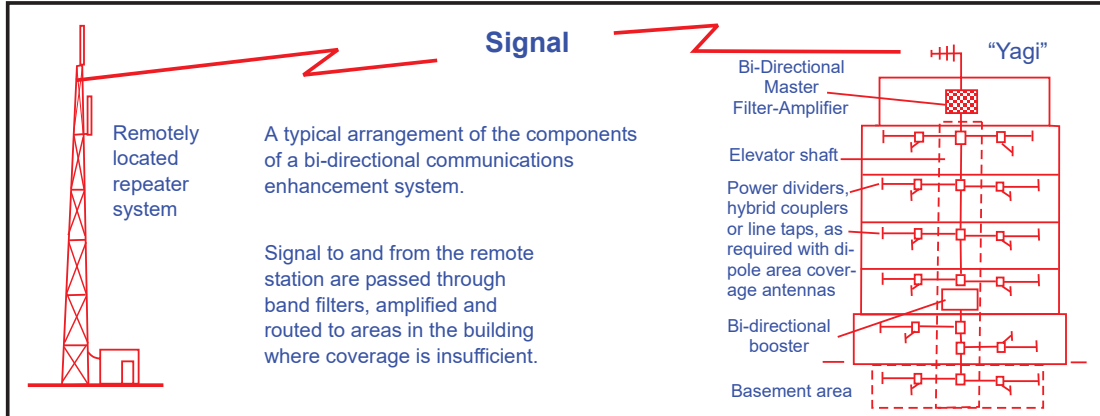

BENEFITS & FEATURES OF EMR CORPORATION ENHANCEMENT SYSTEMS:

- Designed specifically to meet your enhancement needs.
- Amplifiers are unique to enhancement signal characteristics and F.C.C. type accepted.
- System gain set provisions and signal overload protection assures optimum performance.
- Filtering is custom designed and tuned to meet individual system requirements.
- Ultra reliable - Field tested designs utilizing the highest quality components.
- Five year warranty
- System design assistance provided. We will ask you to provide details of the structure(s) to be enhanced. Certain measurements and tests must often be made in order that signal distribution may be determined. This work can be accomplished by your technical staff or EMR Corp.

VHF Bi-Directional Amplifier System

Electrical Specifications

FCC Classification	Class B Signal Booster
Frequency Band	150-176 MHz
Passband Width	≤ 1 MHz
Stopband Width	≥ 4 MHz
Amplifier Gain (Typ.)	75 dB
System Gain (Typ.)	60 dB
Amplifier O/P Power (Max.)	+37 dBm
PA Power Control Setpoint	+37 dBm
Power Control Dynamic Range	30 dB
System O/P Power	Note 1
Amplifier Noise Figure	3.0 dB
System Noise Figure	Note 2
IP3	+50 dBm
Nominal Impedance	50 Ohm
VSWR (Max.)	1.35:1
Amplifier Bias Voltage	13.6 VDC
System Voltage	115 VAC (Optional 12 VDC, 24 VDC, 48 VDC, 220 VAC)
RF Connectors	N Female

Mechanical Specifications

Finish	Red
Enclosure Type	NEMA-4
Overall Size (HxWxD)	18.5" x 13.75" x 7.25" (470 x 349 x 184 mm)
Ship Weight	40 lbs (18 kg)

Environmental Specifications

Operating Temp. Range	-20°F to +50°C
Operating Humidity Range	0-90% non-condensing

NOTES

Note 1: System output power is a function of the number of carriers incident on the system, the signal level of these carriers to the signal enhancement system, gain of the PA's, and the insertion loss of the filters within the bidirectional system.

Note 2: System Noise Figure is the sum of the amplifier NF and the filter losses prior to the amplifier. The filter losses are dependent on the passband width for the uplink frequencies, the passband width for the downlink frequencies, and the stop band between them.

"WARNING. This is NOT a CONSUMER device. It is designed for installation by FCC LICENSEES and QUALIFIED INSTALLERS. You MUST have an FCC LICENSE or express consent of an FCC Licensee to operate this device. You MUST register Class B signal boosters (as defined in 47 CFR 90.219) online at www.fcc.gov/signal-boosters/registration. Unauthorized use may result in significant forfeiture penalties, including penalties in excess of \$100,000 for each continuing violation."

[78 FR 21564, Apr. 12, 2013]

EMR Bi-Directional Amplifiers (BDA's) provide two way (uplink and downlink) filtering and amplification of RF signals in buildings, tunnels or areas that are shaded from adequate RF signal coverage. In addition to the BDA, other devices needed for a distribution system include transmission line, power splitters, hybrid & directional couplers and indoor antennas. The use of radiating cable can also be used, particularly in tunnels and long corridors. The choice of distribution method depends on the nature of the structure in which signal enhancement is required.

Optional System Upgrades

- Fiber Optic DAS
- Alarm & Monitoring
- Battery Backup 12, 24 hour
- Higher gain



VHF Bi-Directional Amplifier System

Electrical Specifications

FCC Classification	Class B Signal Booster
Frequency Band	150-174 MHz
Passband Width	≤ 1.5 MHz
Stopband Width	≥ 3.5 MHz
Amplifier Gain (Typ.)	75 dB
System Gain (Typ.)	60 dB
Amplifier O/P Power (Max.)	+37 dBm
PA Power Control Setpoint	+37 dBm
Power Control Dynamic Range	30 dB
System O/P Power	Note 1
Amplifier Noise Figure	3.0 dB
System Noise Figure	Note 2
IP3	+50 dBm
Nominal Impedance	50 Ohm
VSWR (Max.)	1.35:1
Amplifier Bias Voltage	13.6 VDC
System Voltage	115 VAC (Optional 12 VDC, 24 VDC, 48 VDC, 220 VAC)
RF Connectors	N Female

Mechanical Specifications

Finish	Red
Enclosure Type	NEMA-4
Overall Size (HxWxD)	18.5" x 13.75" x 7.25" (470 x 349 x 184 mm)
Ship Weight	40 lbs (18 kg)

Environmental Specifications

Operating Temp. Range	-20°F to +50°C
Operating Humidity Range	0-90% non-condensing

NOTES

Note 1: System output power is a function of the number of carriers incident on the system, the signal level of these carriers to the signal enhancement system, gain of the PA's, and the insertion loss of the filters within the bidirectional system.

Note 2: System Noise Figure is the sum of the amplifier NF and the filter losses prior to the amplifier. The filter losses are dependent on the passband width for the uplink frequencies, the passband width for the downlink frequencies, and the stop band between them.

"WARNING: This is NOT a CONSUMER device. It is designed for installation by FCC LICENSEES and QUALIFIED INSTALLERS. You MUST have an FCC LICENSE or express consent of an FCC Licensee to operate this device. You MUST register Class B signal boosters (as defined in 47 CFR 90.219) online at www.fcc.gov/signal-boosters/registration. Unauthorized use may result in significant forfeiture penalties, including penalties in excess of \$100,000 for each continuing violation."

EMR Bi-Directional Amplifiers (BDA's) provide two way (uplink and downlink) filtering and amplification of RF signals in buildings, tunnels or areas that are shaded from adequate RF signal coverage. In addition to the BDA, other devices needed for a distribution system include transmission line, power splitters, hybrid & directional couplers and indoor antennas. The use of radiating cable can also be used, particularly in tunnels and long corridors. The choice of distribution method depends on the nature of the structure in which signal enhancement is required.

Optional System Upgrades

- Fiber Optic DAS
- Alarm & Monitoring
- Battery Backup 12, 24 hour
- Higher gain



UHF Bi-Directional Amplifier System

Electrical Specifications

FCC Classification	Class B Signal Booster
Frequency Band	440-512 MHz
Passband Width	≤ 1.5 MHz
Stopband Width	≥ 3.5 MHz
Amplifier Gain (Typ.)	72 dB
System Gain (Typ.)	60 dB
Amplifier O/P Power (Max.)	+37 dBm
PA Power Control Setpoint	+37 dBm
Power Control Dynamic Range	30 dB
System O/P Power	Note 1
Amplifier Noise Figure	3.0 dB
System Noise Figure	Note 2
IP3	+50 dBm
Nominal Impedance	50 Ohm
VSWR (Max.)	1.35:1
Amplifier Bias Voltage	13.6 VDC
System Voltage	115 VAC (Optional 12 VDC, 24 VDC, 48 VDC, 220 VAC)
RF Connectors	N Female

Mechanical Specifications

Finish	Red
Enclosure Type	NEMA-4
Overall Size (HxWxD)	22.5" x 17.75" x 7.25" (508 x 451 x 184 mm)
Ship Weight	60 lbs (27 kg)

Environmental Specifications

Operating Temp. Range	-20°F to +50°C
Operating Humidity Range	0-90% non-condensing

NOTES

Note 1: System output power is a function of the number of carriers incident on the system, the signal level of these carriers to the signal enhancement system, gain of the PA's, and the insertion loss of the filters within the bidirectional system.

Note 2: System Noise Figure is the sum of the amplifier NF and the filter losses prior to the amplifier. The filter losses are dependent on the passband width for the uplink frequencies, the passband width for the downlink frequencies, and the stop band between them.

"WARNING. This is NOT a CONSUMER device. It is designed for installation by FCC LICENSEES and QUALIFIED INSTALLERS. You MUST have an FCC LICENSE or express consent of an FCC Licensee to operate this device. You MUST register Class B signal boosters (as defined in 47 CFR 90.219) online at www.fcc.gov/signal-boosters/registration. Unauthorized use may result in significant forfeiture penalties, including penalties in excess of \$100,000 for each continuing violation."

[78 FR 21564, Apr. 12, 2013]

EMR Bi-Directional Amplifiers (BDA's) provide two way (uplink and downlink) filtering and amplification of RF signals in buildings, tunnels or areas that are shaded from adequate RF signal coverage. In addition to the BDA, other devices needed for a distribution system include transmission line, power splitters, hybrid & directional couplers and indoor antennas. The use of radiating cable can also be used, particularly in tunnels and long corridors. The choice of distribution method depends on the nature of the structure in which signal enhancement is required.

Optional System Upgrades

- Fiber Optic DAS
- Alarm & Monitoring
- Battery Backup 12, 24 hour
- Higher gain



UHF Bi-Directional Amplifier System

Electrical Specifications

FCC Classification	Class B Signal Booster
Frequency Band	440-512 MHz
Passband Width	≤ 2 MHz
Stopband Width	≥ 3 MHz
Amplifier Gain (Typ.)	72 dB
System Gain (Typ.)	60 dB
Amplifier O/P Power (Max.)	+37 dBm
PA Power Control Setpoint	+37 dBm
Power Control Dynamic Range	30 dB
System O/P Power	Note 1
Amplifier Noise Figure	3.0 dB
System Noise Figure	Note 2
IP3	+50 dBm
Nominal Impedance	50 Ohm
VSWR (Max.)	1.35:1
Amplifier Bias Voltage	13.6 VDC
System Voltage	115 VAC (Optional 12 VDC, 24 VDC, 48 VDC, 220 VAC)
RF Connectors	N Female

Mechanical Specifications

Finish	Red
Enclosure Type	NEMA-4
Overall Size (HxWxD)	22.5" x 17.75" x 7.25" (508 x 451 x 184 mm)
Ship Weight	60 lbs (27 kg)

Environmental Specifications

Operating Temp. Range	-20°F to +50°C
Operating Humidity Range	0-90% non-condensing

NOTES

Note 1: System output power is a function of the number of carriers incident on the system, the signal level of these carriers to the signal enhancement system, gain of the PA's, and the insertion loss of the filters within the bidirectional system.

Note 2: System Noise Figure is the sum of the amplifier NF and the filter losses prior to the amplifier. The filter losses are dependent on the passband width for the uplink frequencies, the passband width for the downlink frequencies, and the stop band between them.

"WARNING. This is NOT a CONSUMER device. It is designed for installation by FCC LICENSEES and QUALIFIED INSTALLERS. You MUST have an FCC LICENSE or express consent of an FCC Licensee to operate this device. You MUST register Class B signal boosters (as defined in 47 CFR 90.219) online at www.fcc.gov/signal-boosters/registraton. Unauthorized use may result in significant forfeiture penalties, including penalties in excess of \$100,000 for each continuing violation."

EMR Bi-Directional Amplifiers (BDA's) provide two way (uplink and downlink) filtering and amplification of RF signals in buildings, tunnels or areas that are shaded from adequate RF signal coverage. In addition to the BDA, other devices needed for a distribution system include transmission line, power splitters, hybrid & directional couplers and indoor antennas. The use of radiating cable can also be used, particularly in tunnels and long corridors. The choice of distribution method depends on the nature of the structure in which signal enhancement is required.

Optional System Upgrades

- Fiber Optic DAS
- Alarm & Monitoring
- Battery Backup 12, 24 hour
- Higher gain



900 Class B Bi-Directional Amplifier System

Electrical Specifications

FCC Classification	Class B Signal Booster
Frequency Band	896 - 940 MHz
Passband Width	≤ 5 MHz
Stopband Width	≥ 34 MHz
Amplifier Gain (Typ.)	68 dB
System Gain (Typ.)	60 dB
Amplifier O/P Power (Max.)	+37 dBm
PA Power Control Setpoint	+37 dBm
Power Control Dynamic Range	30 dB
System O/P Power	Note 1
Amplifier Noise Figure	3.0 dB
System Noise Figure	Note 2
IP3	+50 dBm
Nominal Impedance	50 Ohm
VSWR (Max.)	1.35:1
Amplifier Bias Voltage	13.6 VDC
System Voltage	115 VAC (Optional 12 VDC, 24 VDC, 48 VDC, 220 VAC)
RF Connectors	N Female

Mechanical Specifications

Finish	Red
Enclosure Type	NEMA-4
Overall Size (HxWxD)	18.5" x 13.75" x 7.25" (470 x 349 x 184 mm)
Ship Weight	40 lbs (18 kg)

Environmental Specifications

Operating Temp. Range	-20°F to +50°C
Operating Humidity Range	0-90% non-condensing

NOTES

Note 1: System output power is a function of the number of carriers incident on the system, the signal level of these carriers to the signal enhancement system, gain of the PA's, and the insertion loss of the filters within the bidirectional system.

Note 2: System Noise Figure is the sum of the amplifier NF and the filter losses prior to the amplifier. The filter losses are dependent on the passband width for the uplink frequencies, the passband width for the downlink frequencies, and the stop band between them.

"WARNING. This is NOT a CONSUMER device. It is designed for installation by FCC LICENSEES and QUALIFIED INSTALLERS. You MUST have an FCC LICENSE or express consent of an FCC Licensee to operate this device. You MUST register Class B signal boosters (as defined in 47 CFR 90.219) online at www.fcc.gov/signal-boosters/registration. Unauthorized use may result in significant forfeiture penalties, including penalties in excess of \$100,000 for each continuing violation."

[78 FR 21564, Apr. 12, 2013]

All product specifications subject to change without notice.

Copyright © 2018 EMR Corporation. All rights reserved.

EMR Bi-Directional Amplifiers (BDA's) provide two way (uplink and downlink) filtering and amplification of RF signals in buildings, tunnels or areas that are shaded from adequate RF signal coverage. In addition to the BDA, other devices needed for a distribution system include transmission line, power splitters, hybrid & directional couplers and indoor antennas. The use of radiating cable can also be used, particularly in tunnels and long corridors. The choice of distribution method depends on the nature of the structure in which signal enhancement is required.

Optional System Upgrades

- Fiber Optic DAS
- Alarm & Monitoring
- Battery Backup 12, 24 hour
- Higher gain



800 Class B Bi-Directional Amplifier System

Electrical Specifications

FCC Classification	Class B Signal Booster
Frequency Band	806 - 861 MHz
Passband Width	≤ 10 MHz
Stopband Width	≥ 35 MHz
Amplifier Gain (Typ.)	68 dB
System Gain (Typ.)	60 dB
Amplifier O/P Power (Max.)	+37 dBm
PA Power Control Setpoint	+37 dBm
Power Control Dynamic Range	30 dB
System O/P Power	Note 1
Amplifier Noise Figure	3.0 dB
System Noise Figure	Note 2
IP3	+50 dBm
Nominal Impedance	50 Ohm
VSWR (Max.)	1.35:1
Amplifier Bias Voltage	13.6 VDC
System Voltage	115 VAC (Optional 12 VDC, 24 VDC, 48 VDC, 220 VAC)
RF Connectors	N Female

Mechanical Specifications

Finish	Red
Enclosure Type	NEMA-4
Overall Size (HxWxD)	18.5" x 13.75" x 7.25" (470 x 349 x 184 mm)
Ship Weight	40 lbs (18 kg)

Environmental Specifications

Operating Temp. Range	-20°F to +50°C
Operating Humidity Range	0-90% non-condensing

NOTES

Note 1: System output power is a function of the number of carriers incident on the system, the signal level of these carriers to the signal enhancement system, gain of the PA's, and the insertion loss of the filters within the bidirectional system.

Note 2: System Noise Figure is the sum of the amplifier NF and the filter losses prior to the amplifier. The filter losses are dependent on the passband width for the uplink frequencies, the passband width for the downlink frequencies, and the stop band between them.

“WARNING. This is NOT a CONSUMER device. It is designed for installation by FCC LICENSEES and QUALIFIED INSTALLERS. You MUST have an FCC LICENSE or express consent of an FCC Licensee to operate this device. You MUST register Class B signal boosters (as defined in 47 CFR 90.219) online at www.fcc.gov/signal-boosters/registration. Unauthorized use may result in significant forfeiture penalties, including penalties in excess of \$100,000 for each continuing violation.”

[78 FR 21564, Apr. 12, 2013]

EMR Bi-Directional Amplifiers (BDA's) provide two way (uplink and downlink) filtering and amplification of RF signals in buildings, tunnels or areas that are shaded from adequate RF signal coverage. In addition to the BDA, other devices needed for a distribution system include transmission line, power splitters, hybrid & directional couplers and indoor antennas. The use of radiating cable can also be used, particularly in tunnels and long corridors. The choice of distribution method depends on the nature of the structure in which signal enhancement is required.

Optional System Upgrades

- Fiber Optic DAS
- Alarm & Monitoring
- Battery Backup 12, 24 hour
- Higher gain



VHF Uni-Directional Amplifier System

Electrical Specifications

FCC Classification	Class B Signal Booster
Frequency Band	150-176 MHz
Passband Width	≤ 1.5 MHz
Amplifier Gain (Typ.)	75 dB
System Gain (Typ.)	65 dB
Amplifier O/P Power (Max.)	+37 dBm
PA Power Control Setpoint	+37 dBm
Power Control Dynamic Range	30 dB
System O/P Power	Note 1
Amplifier Noise Figure	3.0 dB
System Noise Figure	Note 2
IP3	+50 dBm
Nominal Impedance	50 Ohm
VSWR (Max.)	1.35:1
Amplifier Bias Voltage	13.6 VDC
System Voltage	115 VAC (Optional 12 VDC, 24 VDC, 48 VDC, 220 VAC)
RF Connectors	N Female

Mechanical Specifications

Finish	Red
Enclosure Type	NEMA-4
Overall Size (HxWxD)	18.5" x 13" x 7.25" (470 x 330 x 184 mm)
Ship Weight	30 lbs (13.6 kg)

Environmental Specifications

Operating Temp. Range	-20°F to +50°C
Storage Temp Range	-40°C to +85°C
Operating Humidity Range	0-90% non-condensing

NOTES

Note 1: System output power is a function of the number of carriers incident on the system, the signal level of these carriers to the signal enhancement system, gain of the PA's, and the insertion loss of the filters within the bidirectional system.

Note 2: System Noise Figure is the sum of the amplifier NF and the filter losses prior to the amplifier. The filter losses are dependent on the passband width for the uplink frequencies, the passband width for the downlink frequencies, and the stop band between them.

"WARNING. This is NOT a CONSUMER device. It is designed for installation by FCC LICENSEES and QUALIFIED INSTALLERS. You MUST have an FCC LICENSE or express consent of an FCC Licensee to operate this device. You MUST register Class B signal boosters (as defined in 47 CFR 90.219) online at www.fcc.gov/signal-boosters/registration. Unauthorized use may result in significant forfeiture penalties, including penalties in excess of \$100,000 for each continuing violation."

[78 FR 21564, Apr. 12, 2013]

EMR Uni-Directional Amplifiers (UDA's) provide a one way link (either uplink or downlink) inclusive of filtering and amplification of paging or base transmit signals into buildings, tunnels or areas that are shaded from adequate RF signal coverage, of portable transmit signals out. In addition to the UDA, other devices needed for a distribution system include transmission line, power splitters, hybrid & directional couplers, donor antenna, and Distributed Antenna System (DAS) antennas. Suitable for coaxial or radiating cable DAS. The choice of distribution method depends on the nature of the structure in which signal enhancement is required.

Optional System Upgrades

- Fiber Optic DAS
- Alarm & Monitoring
- Battery Backup 12, 24 hour
- Higher gain



UHF Uni-Directional Amplifier System

Electrical Specifications

FCC Classification	Class B Signal Booster
Frequency Band	440-470 MHz
Passband Width	≤ 1.5 MHz
Amplifier Gain (Typ.)	72 dB
System Gain (Typ.)	65 dB
Amplifier O/P Power (Max.)	+37 dBm
PA Power Control Setpoint	+37 dBm
Power Control Dynamic Range	30 dB
System O/P Power	Note 1
Amplifier Noise Figure	3.0 dB
System Noise Figure	Note 2
IP3	+50 dBm
Nominal Impedance	50 Ohm
VSWR (Max.)	1.35:1
Amplifier Bias Voltage	13.6 VDC
System Voltage	115 VAC (Optional 12 VDC, 24 VDC, 48 VDC, 220 VAC)
RF Connectors	N Female

Mechanical Specifications

Finish	Red
Enclosure Type	NEMA-4
Overall Size (HxWxD)	18.5" x 13" x 7.25" (470 x 330 x 184 mm)
Ship Weight	30 lbs (13.6 kg)

Environmental Specifications

Operating Temp. Range	-20°F to +50°C
Operating Humidity Range	0-90% non-condensing

NOTES

Note 1: System output power is a function of the number of carriers incident on the system, the signal level of these carriers to the signal enhancement system, gain of the PA's, and the insertion loss of the filters within the bidirectional system.

Note 2: System Noise Figure is the sum of the amplifier NF and the filter losses prior to the amplifier. The filter losses are dependent on the passband width for the uplink frequencies, the passband width for the downlink frequencies, and the stop band between them.

"WARNING. This is NOT a CONSUMER device. It is designed for installation by FCC LICENSEES and QUALIFIED INSTALLERS. You MUST have an FCC LICENSE or express consent of an FCC Licensee to operate this device. You MUST register Class B signal boosters (as defined in 47 CFR 90.219) online at www.fcc.gov/signal-boosters/registration. Unauthorized use may result in significant forfeiture penalties, including penalties in excess of \$100,000 for each continuing violation."

[78 FR 21564, Apr. 12, 2013]

EMR Uni-Directional Amplifiers (UDA's) provide a one way link (either uplink or downlink) inclusive of filtering and amplification of paging or base transmit signals into buildings, tunnels or areas that are shaded from adequate RF signal coverage, of portable transmit signals out. In addition to the UDA, other devices needed for a distribution system include transmission line, power splitters, hybrid & directional couplers, donor antenna, and Distributed Antenna System (DAS) antennas. Suitable for coaxial or radiating cable DAS. The choice of distribution method depends on the nature of the structure in which signal enhancement is required.

Optional System Upgrades

- Fiber Optic DAS
- Alarm & Monitoring
- Battery Backup 24 hour
- Higher gain



900 Uni-Directional Amplifier System

Electrical Specifications

FCC Classification	Class B Signal Booster
Frequency Band	896-960 MHz
Passband Width	≤ 5 MHz
Amplifier Gain (Typ.)	68 dB
System Gain (Typ.)	60 dB
Amplifier O/P Power (Max.)	+37 dBm
PA Power Control Setpoint	+37 dBm
Power Control Dynamic Range	30 dB
System O/P Power	Note 1
Amplifier Noise Figure	3.0 dB
System Noise Figure	Note 2
IP3	+50 dBm
Nominal Impedance	50 Ohm
VSWR (Max.)	1.35:1
Amplifier Bias Voltage	13.6 VDC
System Voltage	115 VAC (Optional 12 VDC, 24 VDC, 48 VDC, 220 VAC)
RF Connectors	N Female

Mechanical Specifications

Finish	Red
Enclosure Type	NEMA-4
Overall Size (HxWxD)	18.5" x 13" x 7.25" (470 x 330 x 184 mm)
Ship Weight	30 lbs (13.6 kg)

Environmental Specifications

Operating Temp. Range	-20°F to +50°C
Operating Humidity Range	0-90% non-condensing

EMR Uni-Directional Amplifiers (UDA's) provide a one way link (either uplink or downlink) inclusive of filtering and amplification of paging or base transmit signals into buildings, tunnels or areas that are shaded from adequate RF signal coverage, of portable transmit signals out. In addition to the UDA, other devices needed for a distribution system include transmission line, power splitters, hybrid & directional couplers, donor antenna, and Distributed Antenna System (DAS) antennas. Suitable for coaxial or radiating cable DAS. The choice of distribution method depends on the nature of the structure in which signal enhancement is required.

Optional System Upgrades

- Fiber Optic DAS
- Alarm & Monitoring
- Battery Backup 12, 24 hour
- Higher gain



NOTES

Note 1: System output power is a function of the number of carriers incident on the system, the signal level of these carriers to the signal enhancement system, gain of the PA's, and the insertion loss of the filters within the bidirectional system.

Note 2: System Noise Figure is the sum of the amplifier NF and the filter losses prior to the amplifier. The filter losses are dependent on the passband width for the uplink frequencies, the passband width for the downlink frequencies, and the stop band between them.

"WARNING. This is NOT a CONSUMER device. It is designed for installation by FCC LICENSEES and QUALIFIED INSTALLERS. You MUST have an FCC LICENSE or express consent of an FCC Licensee to operate this device. You MUST register Class B signal boosters (as defined in 47 CFR 90.219) online at www.fcc.gov/signal-boosters/registration. Unauthorized use may result in significant forfeiture penalties, including penalties in excess of \$100,000 for each continuing violation."

[78 FR 21564, Apr. 12, 2013]

BDA Remote Power Monitor

BDAMON2 Specifications

24/7 System Monitoring	Yes
Door Alarm	Yes
AC Power Alarm	Yes
DC Power Alarm	Yes
RF Amp. Functions Alarm	Yes
NFPA Compliance	Yes
Email Notifications	Up to 5
View Alarm Conditions	Via Web Page
Monitor Alarm Reset	Via Web Page
Supervisory Signals	Antenna Malfunction, Battery Charger Failure, Loss of Normal AC Power, Low Battery Capacity, Signal Booster Failure

Mechanical Specifications

Finish	Black Anodized
Overall Size (HxWxD)	2" x 9" x 1.5" (51 x 229 x 38 mm)
Net Weight	0.7 lbs (0.3 kg)

Environmental Specifications

Operating Temp. Range	-30 to +60 °C
Storage Temp. Range	-40 to +85°C
Operating Humidity Range	0-90% non-condensing
Storage Humidity Range	0-95% non-condensing
Storage and Transport Alt. Range	0 to 25,000'



The EMR BDAMON Series BDA Power Monitor is an optional upgrade consisting of a microprocessor controlled unit which monitors power supply, primary AC voltage, battery DC voltage, DC current, and door status alarm for up to four RF amplifiers installed in any EMR signal enhancement system. Monitoring features available vary based on the relevant hardware configuration of the BDA. The BDAMON interface is accessed via a web browser and IP/DNS configurable for remote access and messaging for up to 5 email addresses.

Product Features

- Monitoring for up to four RF power amplifiers
- Web access
- Door open/close alarm
- AC & DC power alarm
- Power supply alarm
- LED status indicators
- IP/DNS configuration
- Email notification for up to five addresses
- SNMP trap
- Reduce service calls
- NFPA72 compliant

EMR BDA System with BDAMON2 installed.



RF Line Tap

Electrical Specifications

Frequency Band	150-174 MHz
# Tap Points	1
Input Power (Max.)	250 W
Power Ratio ThruLine:Coupled-Ports	99:1 (20dB), 96:4 (15dB), 90:10 (10dB), 75:25 (6dB)
Coupling Tolerance	± 1.0 dB
Coupling Range	Adjustable
VSWR (Max.)	1.5:1
Impedance (Nom.)	50 Ω
RF Connectors	N Female

Mechanical Specifications

Finish	Gray Paint
Overall Size (HxWxD)	1.75" x 4.425" x 1.1" (44 x 112 x 28 mm)
Net Weight	0.42 lbs (0.2 kg)
Ship Weight	2 lbs (0.9 kg)

Environmental Specifications

Application	Indoor
Operating Temp. Range	-20 to +50 °C
Storage Temp. Range	-40 to +100 °C
Operating Humidity Range	90% Non-condensing



EMR RF Line Taps are available in three or four port versions, factory tuned per application. Input power is the sum of the output power and the tapped power. These bi-directional line taps handle up to 250W power with coupler lengths corresponding to the operating frequency for unmatched efficiency and reliability.

Product Features

- Available in VHF, UHF, 700, 800 & 900 MHz
- Up to 250 Watts power
- Excellent Impedance Match
- Field Adjustable

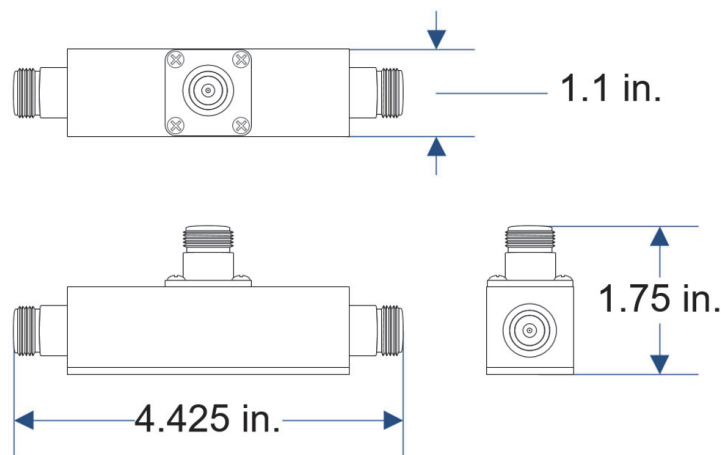

RF Line Tap

Electrical Specifications

Frequency Band	300-650 MHz
# Tap Points	1
Input Power (Max.)	250 W
Power Ratio ThruLine:Coupled-Ports	99:1 (20dB), 96:4 (15dB), 90:10 (10dB), 75:25 (6dB)
Coupling Tolerance	± 1.0 dB
Coupling Range	Adjustable
VSWR (Max.)	1.5:1
Impedance (Nom.)	50 Ω
RF Connectors	N Female

Mechanical Specifications

Finish	Gray Paint
Overall Size (HxWxD)	1.75" x 4.425" x 1.1" (44 x 112 x 28 mm)
Net Weight	0.42 lbs (0.2 kg)
Ship Weight	2 lbs (0.9 kg)

Environmental Specifications

Application	Indoor
Operating Temp. Range	-20 to +50 °C
Storage Temp. Range	-40 to +100 °C
Operating Humidity Range	90% Non-condensing



EMR RF Line Taps are available in three or four port versions, factory tuned per application. Input power is the sum of the output power and the tapped power. These bi-directional line taps handle up to 250W power with coupler lengths corresponding to the operating frequency for unmatched efficiency and reliability.

Product Features

- Available in VHF, UHF, 700, 800 & 900 MHz
- Up to 250 Watts power
- Excellent Impedance Match
- Field Adjustable

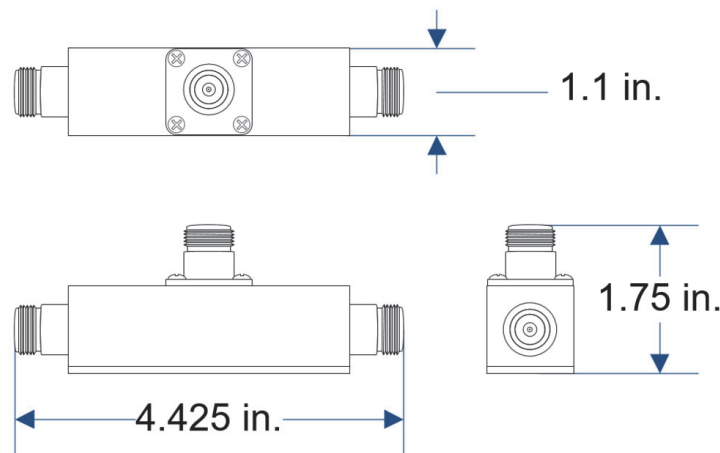

RF Line Tap

Electrical Specifications

Frequency Band	650-1000 MHz
# Tap Points	1
Input Power (Max.)	250 W
Power Ratio ThruLine:Coupled-Ports	99:1 (20dB), 96:4 (15dB), 90:10 (10dB), 75:25 (6dB)
Coupling Tolerance	± 1.0 dB
Coupling Range	Adjustable
VSWR (Max.)	1.5:1
Impedance (Nom.)	50 Ω
RF Connectors	N Female

Mechanical Specifications

Finish	Gray Paint
Overall Size (HxWxD)	1.75" x 4.425" x 1.1" (44 x 112 x 28 mm)
Net Weight	0.42 lbs (0.2 kg)
Ship Weight	2 lbs (0.9 kg)

Environmental Specifications

Application	Indoor
Operating Temp. Range	-20 to +50 °C
Storage Temp. Range	-40 to +100 °C
Operating Humidity Range	90% Non-condensing



EMR RF Line Taps are available in three or four port versions, factory tuned per application. Input power is the sum of the output power and the tapped power. These bi-directional line taps handle up to 250W power with coupler lengths corresponding to the operating frequency for unmatched efficiency and reliability.

Product Features

- Available in VHF, UHF, 700, 800 & 900 MHz
- Up to 250 Watts power
- Excellent Impedance Match
- Field Adjustable

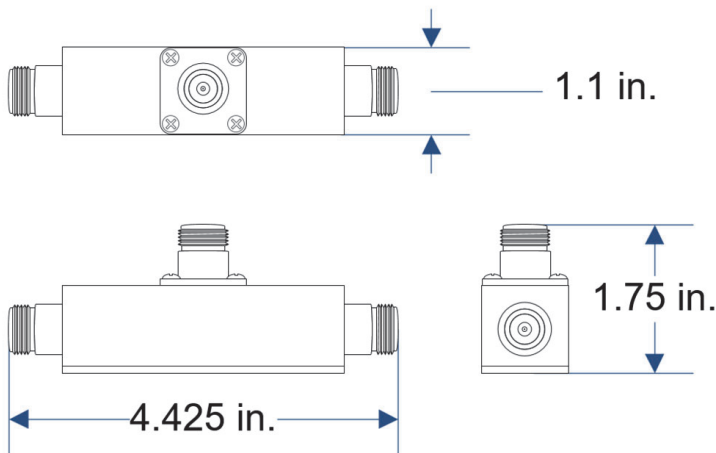

Quarter Wave Antenna

Electrical Specifications

Frequency Band	406-512 MHz
Bandwidth	20 MHz
Gain	Unity
Input Power (Max.)	100 W
VSWR (Max.)	1.5:1
Impedance (Nom.)	50 Ω
RF Connectors	N Male
Radiation Pattern	Omni-Directional

Mechanical Specifications

Finish	EMR Gray
Overall Size (HxWxD)	7" x 12" x 12" (178 x 305 x 305 mm)
Net Weight	1.5 lbs (0.7 kg)
Ship Weight	3 lbs (1.4 kg)

Environmental Specifications

Operating Temp. Range	-22 to 140 °F (-30 to +60 °C)
-----------------------	-------------------------------

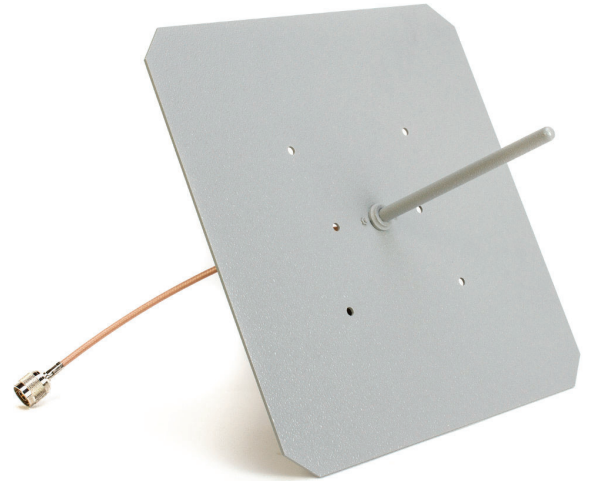

Vertical Plane

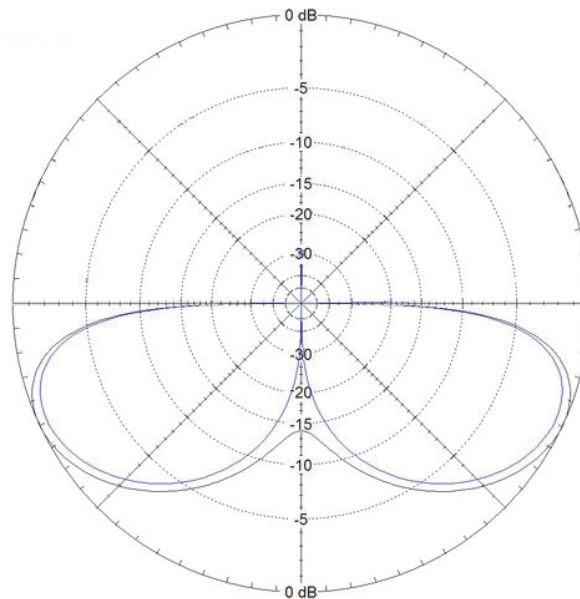

Quarter Wave Antenna

Electrical Specifications

Frequency Band	406-512 MHz
Bandwidth	20 MHz
Gain	Unity
Input Power (Max.)	100 W
VSWR (Max.)	1.5:1
Impedance (Nom.)	50 Ω
RF Connectors	N Female
Radiation Pattern	Omni-Directional

Mechanical Specifications

Finish	EMR Gray
Overall Size (HxWxD)	7" x 12" x 12" (178 x 305 x 305 mm)
Net Weight	1.5 lbs (0.7 kg)
Ship Weight	3 lbs (1.4 kg)

Environmental Specifications

Operating Temp. Range	-22 to 140 °F (-30 to +60 °C)
-----------------------	-------------------------------

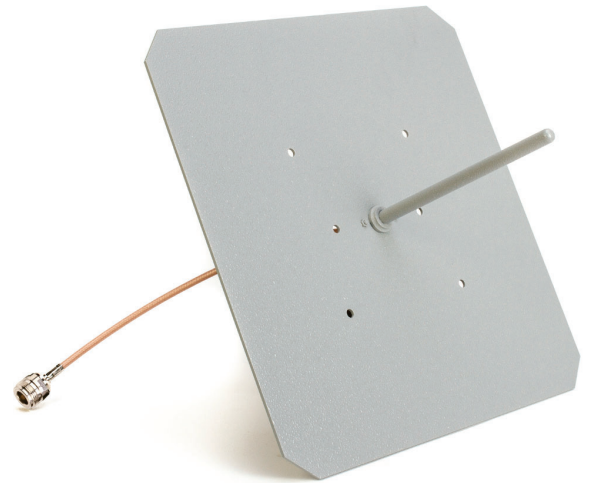

Vertical Plane

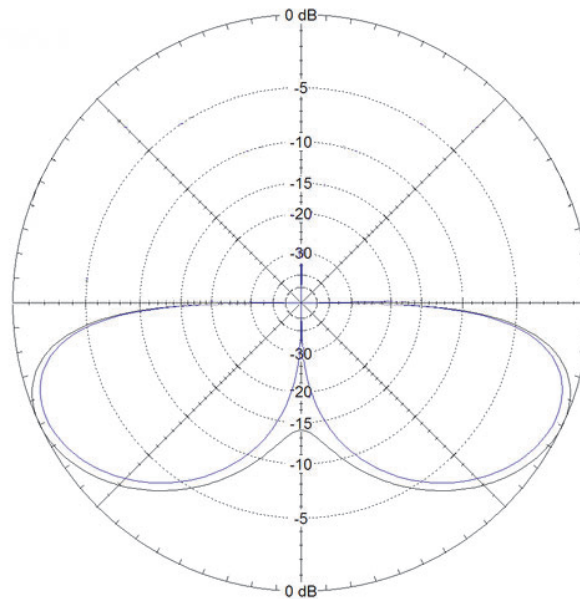

Quarter Wave Antenna

Electrical Specifications

Frequency Band	750-861 MHz
Bandwidth	Full
Gain	Unity
Radiation Pattern	Omni-Directional
Input Power (Max.)	100 W
VSWR (Max.)	1.5:1
Nom. Impedance	50 Ω
RF Connectors	N-Male

Mechanical Specifications

Finish	EMR Gray
Overall Size (HxWxD)	4" x 6" x 6" (102 x 152 x 152 mm)
Net Weight	0.5 lbs (0.2 kg)
Ship Weight	3 lbs (1.4 kg)

Environmental Specifications

Operating Temp. Range	-22 to 140 °F (-30 to +60 °C)
-----------------------	-------------------------------

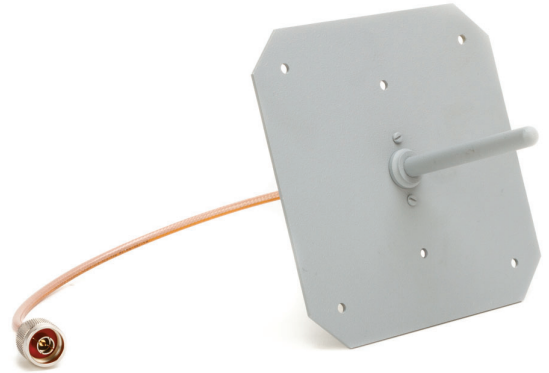

Vertical Plane

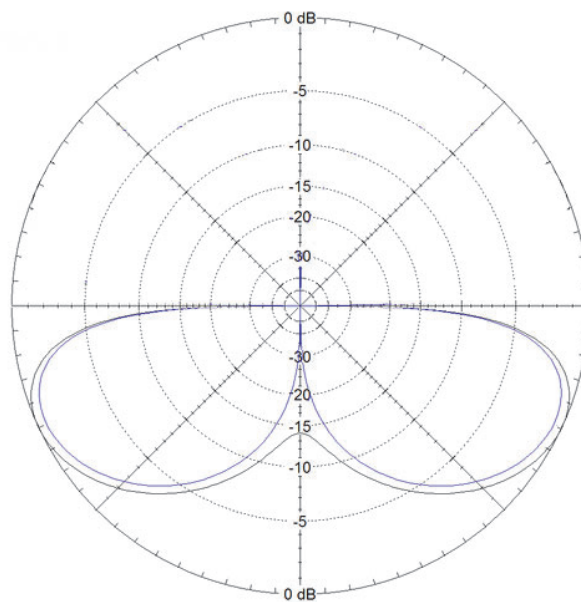

Quarter Wave Antenna

Electrical Specifications

Frequency Band	894-960 MHz
Bandwidth	Full
Gain	Unity
Radiation Pattern	Omni-Directional
Input Power (Max.)	100 W
VSWR (Max.)	1.5:1
Nom. Impedance	50 Ω
RF Connectors	N-Female

Mechanical Specifications

Finish	EMR Gray
Overall Size (HxWxD)	4" x 6" x 6" (102 x 152 x 152 mm)
Net Weight	0.5 lbs (0.2 kg)
Ship Weight	3 lbs (1.4 kg)

Environmental Specifications

Operating Temp. Range	-22 to 140 °F (-30 to +60 °C)
-----------------------	-------------------------------

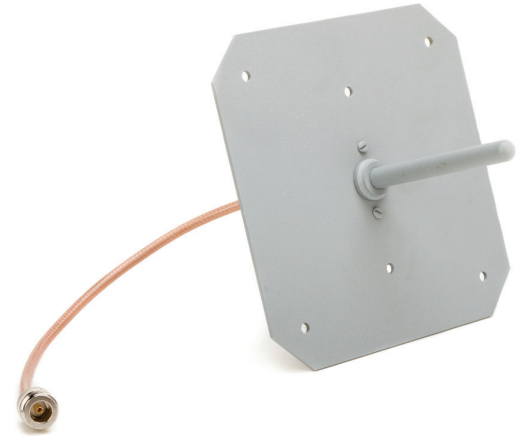

Vertical Plane

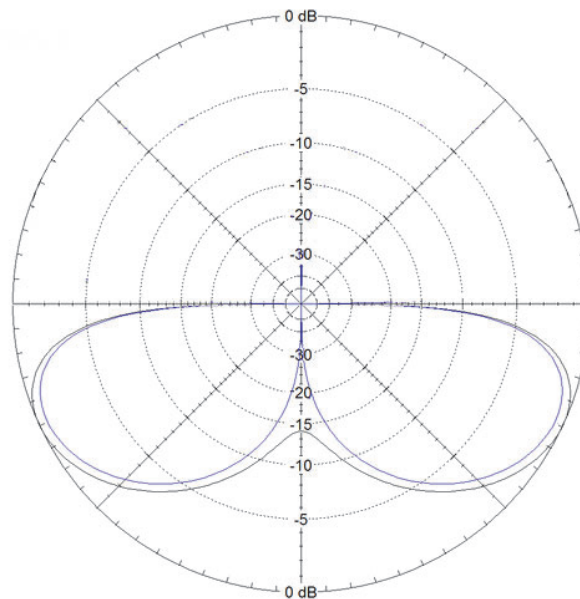

Quarter Wave Antenna

Electrical Specifications

Frequency Band	806-894 MHz
Bandwidth	Full
Gain	Unity
Radiation Pattern	Omni-Directional
Input Power (Max.)	100 W
VSWR (Max.)	1.5:1
Nom. Impedance	50 Ω
RF Connectors	N-Female

Mechanical Specifications

Finish	EMR Gray
Overall Size (HxWxD)	4" x 6" x 6" (102 x 152 x 152 mm)
Net Weight	0.5 lbs (0.2 kg)
Ship Weight	3 lbs (1.4 kg)

Environmental Specifications

Operating Temp. Range	-22 to 140 °F (-30 to +60 °C)
-----------------------	-------------------------------

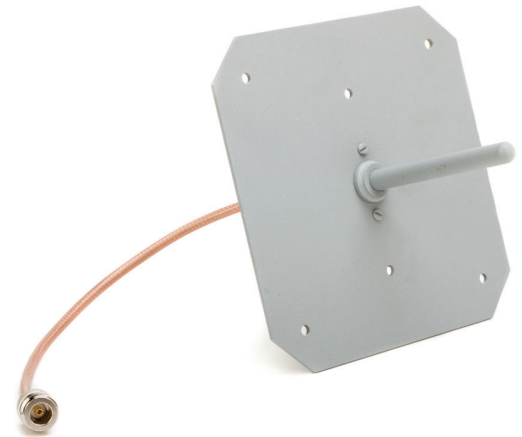

Vertical Plane

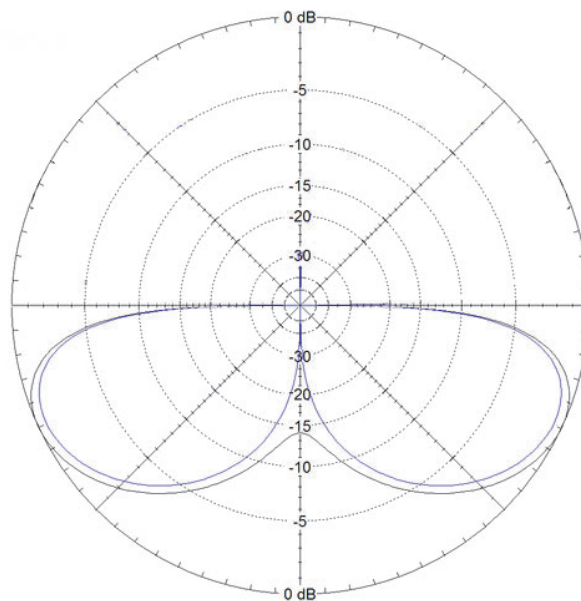

Quarter Wave Antenna

Electrical Specifications

Frequency Band	750-861 MHz
Bandwidth	Full
Gain	Unity
Radiation Pattern	Omni-Directional
RF Connectors	N Female
Input Power (Max.)	100 W
VSWR (Max.)	1.5:1
Impedance (Nom.)	50 Ω

Mechanical Specifications

Finish	EMR Gray
Cable :Length	18.5" (470 mm)
Overall Size (HxWxD)	4" x 6" x 6" (102 x 152 x 152 mm)
Net Weight	0.5 lbs (0.2 kg)
Ship Weight	2 lbs (0.9 kg)

Environmental Specifications

Operating Temp. Range	-22 to 140 °F (-30 to +60 °C)
-----------------------	-------------------------------

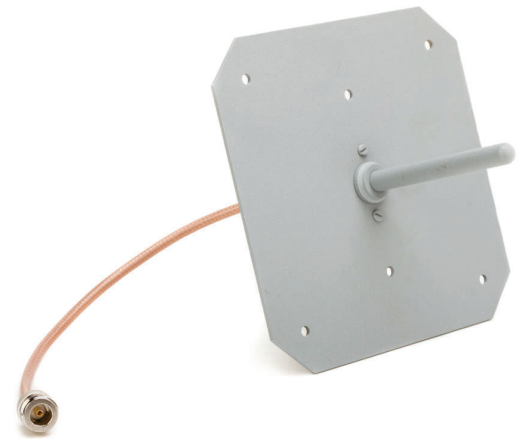

EMR Quarter Wave antennas are omnidirectional, Unity gain, feature a built in metal ground plane, accepting up to 100 watts max power. These antennas are built with durable materials and are painted for corrosion resistance and best power transfer. EMR Quarter Wave antennas are designed to provide coverage solutions for Public Safety Radio frequencies to propagate signals within buildings, tunnels and areas shaded from adequate RF coverage.

Product Features

- Unity Gain
- Corrosion Resistant
- Interior/Exterior Applications
- Ideal for Public Safety

Vertical Plane

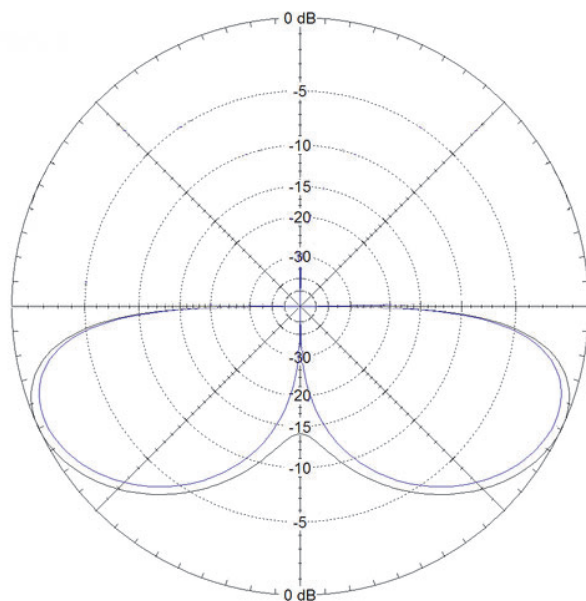

Quarter Wave Antenna

Electrical Specifications

Frequency Band	894-960 MHz
Bandwidth	Full
Gain	Unity
Radiation Pattern	Omni-Directional
Input Power (Max.)	100 W
VSWR (Max.)	1.5:1
Nom. Impedance	50 Ω
RF Connectors	N-Male

Mechanical Specifications

Finish	EMR Gray
Overall Size (HxWxD)	4" x 6" x 6" (102 x 152 x 152 mm)
Net Weight	0.5 lbs (0.2 kg)
Ship Weight	3 lbs (1.4 kg)

Environmental Specifications

Operating Temp. Range	-22 to 140 °F (-30 to +60 °C)
-----------------------	-------------------------------

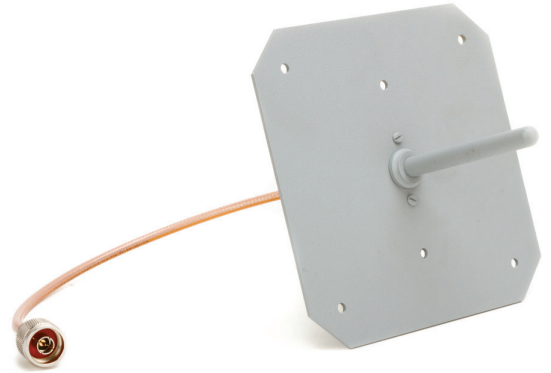

Vertical Plane

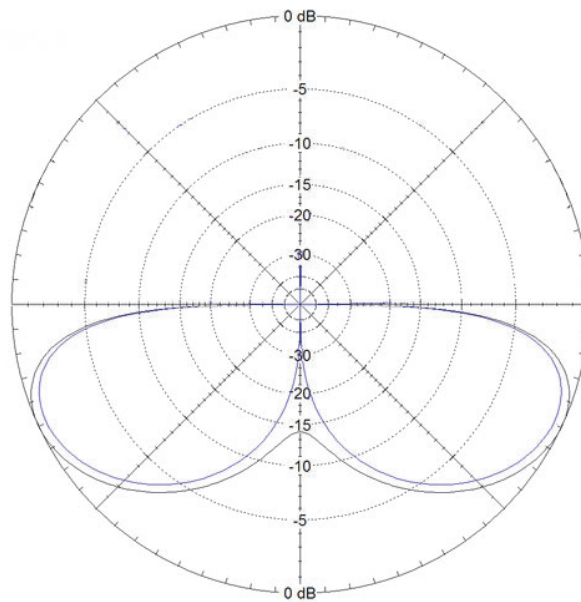



DAS DESIGN SHEET

Uni and Bi-Directional Class B Signal Booster Systems

The following information is required for the design of a DAS solution that has not had a site survey performed. Project schedules depend entirely on the complexity of the design; however, turn around for design proposal and quotation is normally less than five (5) business days after the initial request is received and this form is submitted.

Include the following information when submitting your documentation:

- EMR CORP DAS DESIGN SHEET completed in full (as much information as possible).
- Floor plans of all areas requiring coverage (telecom plans recommended, must be to scale, electronic format in CAD or PDF, verifying floor plans are current).
- All emails must have the Project Name in the "subject" or "reference" line. Do not combine multiple projects in emails.

Customer Information

Company Name: _____

Primary Contact Name: _____

Contact Address: _____

City: _____ State: _____ ZIP: _____

Phone Number(s) Office: _____ Mobile: _____

Email Address: _____

Site Designation: _____

Additional Contact Info: Include additional contact names, phone numbers, emails, etc in the box below.

Technical Information

Specify services to be enhanced:

- Commercial Wireless Services
- Public Safety VHF
- Public Safety UHF
- Public Safety 700 MHz
- Public Safety 800 MHz
- Other: _____

Include frequencies, technologies, and channel count information for all services at end of document.

Define scope of work to be performed by EMR:

- Budgetary
- Design / Full Bill Of Materials

List of Deliverables provided by EMR:

Will Base Transceiver Station (BTS) be used?

- Yes
- No

Outdoor signal strength (roof level preferably or where donor antenna is to be installed) and name/model of equipment used to test:

Repeater ERP: _____ dBm

Test Equipment Used: _____

Distance between repeater site and BDA donor antenna:

Battery Backup (BBU) Required:

- Yes
- No

Indoor RF measurements available:

- Yes
- No

BDA Options:

- High Gain Upgrade
- NFPA Compliant Alarm and Monitoring
- Battery Backup (BBU):
 - 12 Hour 24 Hour
- Fiber Optic Data
 - Number of Fiber Remotes Required: _____

Note: High Gain should only be considered when needed.

Building Information

Building Type: _____

(Open Warehouse, Airport, Mall, Newer Office
Building, Hotel, Parking Garage, Hospital, Older Gov't
Building, University, Courthouse, Prison):

Path Loss Exponent (if known): _____ dB

Current construction stage of the building: Completed
 In Process

Expected project award date: _____
(mm / dd / yyyy)

Composition of exterior roof: _____

Power Requirements (indicate voltage): AC _____
 DC _____

Fiber Requirements: Does fiber already exist?
 No
 Yes
 Single Mode Multi-Mode
How many strands? _____

Is fiber available from the head end to the remote units (as
indicated in floor plans)?
 No
 Yes

List existing system(s) currently installed
in the building (or any other system(s)
operating on a specific radio frequency):

Include the following information on the roof and floor plans of the building(s):

- A. Square footage, dimensions, number of floors requiring coverage.
- B. Location of donor antenna and donor tower (indicated on roof plan).
- C. Location for head end equipment, BDA and all remote units, indicate all locations on floor plans (room should have roof access through riser for donor antenna and power source).
- D. Location of vertical chases, risers, dedicated conduit runs for vertical/horizontal cable in the event of multiple stories.
- E. Areas where radio coverage is critical noted.
- F. Areas where coverage is not desired noted.
- G. Location of hard ceilings noted.
- H. High RF loss materials used in construction noted.

Public Safety VHF / UHF / 700 / 800 MHz

Channel Number	Tx Freq (MHz)	Rx Freq (MHz)	BTS / Off Air	Signal Strength (Donor)	Required DAS Signal Strength
1					
2					
3					
4					
5					
6					
7					
8					
9					
10					
11					
12					
13					
14					
15					
16					
17					
18					

Public Safety 700 / 800 MHz

Band	Class A Required?	Channelized Required?	Channel Count	BTS / Off Air	BBU Required?	Signal Strength (Donor)	Required DAS Signal Strength
700 MHz							
800 MHz							

ORDERING, TERMS & POLICIES

ORDER PLACEMENT: All prices shown are list price, FOB factory (Phoenix Arizona - USA) and are subject to change without prior notice. Prices include domestic packaging and are exclusive of federal, state or local excise or sales taxes, duty or brokerage charges on export shipments. Unless otherwise negotiated freight will be prepaid and added to the invoice.

OPERATING FREQUENCIES: Operating frequencies and power levels used in preparing EMR products are those provided by the customer. Errors in operating frequencies or power levels made by EMR will be corrected at no charge. Errors due to faulty information from the customer are subject to all shipping charges and any material and/or labor cost incurred by EMR Corporation to correct the order.

TERMS OF SALE: Terms of sales are C.O.D., or Cash with Order unless other terms have been established prior to shipment. Open account status will be extended upon reasonable assurance of credit worthiness. Past due accounts are subject to a late charge of up to 2.0% monthly, beginning 30 days after the date of issuance of our valid invoices.

ORDER ACCEPTANCE: An order is considered contractually valid when a purchase order is accepted by mail, telephone, facsimile or e-mail. Cancellations made less than 15 days prior to scheduled ship date may be subject to a cancellation charge.

CLAIMS FOR SHIPPING LOSS OR DAMAGE: All shipments will be made via the customers specified mode of transportation. If coded "best way" the shipment will be consigned to the most economical, reliable commercial carrier. Insurance will be taken unless the customer specifically takes responsibility for shipping loss or damage. Although claims for loss are the responsibility of the consignee, EMR will assist in all ways in making claims and tracking for loss or damage to any of its shipment.

MODIFICATION AND DELAYS: EMR reserves the right to make design changes or modifications to any of its products without specific prior notification provided that such modifications do not materially reduce the value or performance of the equipment concerned. EMR will not be responsible for delays in shipment occasioned by slow or interrupted deliveries to EMR of components, materials or processes necessary to the completion of any project as originally scheduled.

PRODUCT RETURNS: Merchandise returned without having first obtained written acknowledgment from EMR may be rejected. Unless otherwise authorized, credit or refund will not exceed 90% of originally invoiced amounts, and in no event shall include transportation costs. Return authorizations shall expire in 60 days unless otherwise specifically noted.

MECHANICAL SEALS: EMR provides mechanical seals on many of its products. These seals insure that the unit has not been modified or tampered with once it has left the factory. "Breaking" these seals without consent from an authorized EMR Corporation engineer or technician may void the warranty policy stated below.

STANDARD WARRANTY POLICY: EMR Corporation, hereinafter called EMR, warrants that all equipment of its manufacture shall be free from defects in design, material and workmanship for a period of 5 years from date of shipment unless otherwise covered by special warranty. If any such product, entirely or in part, fails to produce the performance as set forth in the brochure, quotations or literature provided by EMR, such product will be replaced or repaired at EMR's expense provided that the failure was not the result of alteration, misuse, tampering, misapplication, shipping damage, vandalism, force majeure or act of God. If a product failure is found to be the fault of EMR the cost of transportation to the EMR factory and its return will be born by EMR. A reasonable charge for travel and subsistence costs will be invoiced when on-site repairs are necessary. Should EMR supply components not of its own manufacture, but specified by a customer, the warranty shall reflect the original manufacturers warranty, only.

It is understood that this statement constitutes EMR's entire and only warranty, there being no other warranties expressed or implied in law or in fact, including implied warranties of fitness. In no event shall EMR be liable for damages, either direct or consequential, that may be occasioned by any defect in material, workmanship or product support.

DESTINATION CONTROL STATEMENT: EMR Corporation strictly adheres to all laws and regulations of the United States Government regarding the export or re-export of our products outside the United States of America. EMR Corporation requires notification regarding the intention to export any products outside the United States of America. Information for the export or re-export requires country of ULTIMATE destination, purchasing individual(s), corporations, financial institution(s), shipping documentation, and shipping entities. This information must be disclosed and on file at EMR Corporation prior to any shipments in accordance with the Export Administration Regulations. Any action contrary to U.S. laws is strictly prohibited.